

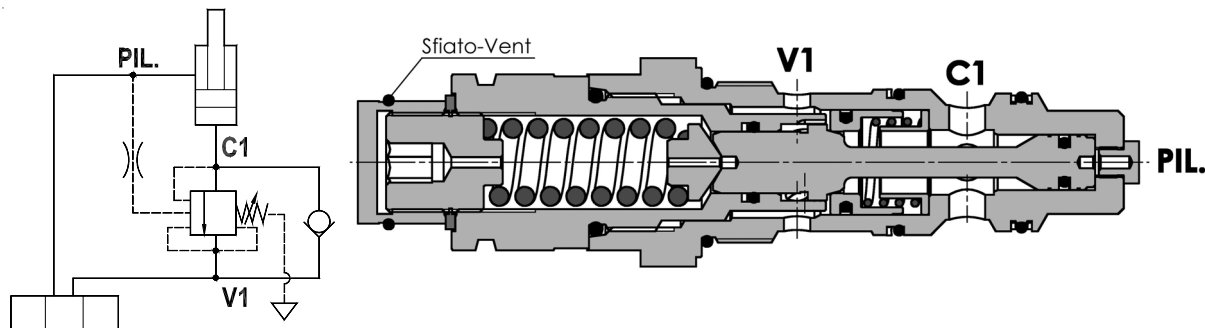

Valvola overcenter bilanciata, versione a cartuccia, cavità metrica
Fully overcenter valve, cartridge version, metric cavity

Rev.04-2010/09

**SPECIFICHE TECNICHE**

Materiali: corpo in acciaio, protetto mediante zincatura. I componenti interni sono in acciaio trattato termicamente.

Portata max.: 300 l/min

Taratura max.: 350 bar

Regolazione pressione: mediante vite

Campo di regolazione pressione: veder pag. 02

TECHNICAL SPECIFICATIONS

Materials: body is steel made. Internal parts are in hardened steel.
 External surface: zinc plated.

Rated flow: 300 l/min

Max. setting: 350 bar

Adjustment means: leakproof screw adjustment

Adjustable pressure range: see page 02

DIAGRAMMA PERDITE DI CARICO - PRESSURE DROP CURVES

Viscosità olio 24 mm²/sec. (3,5 °E)
 Temperatura 50 °C

Oil viscosity 24 mm²/sec. (3,5 °E)
 Temperature 50 °C

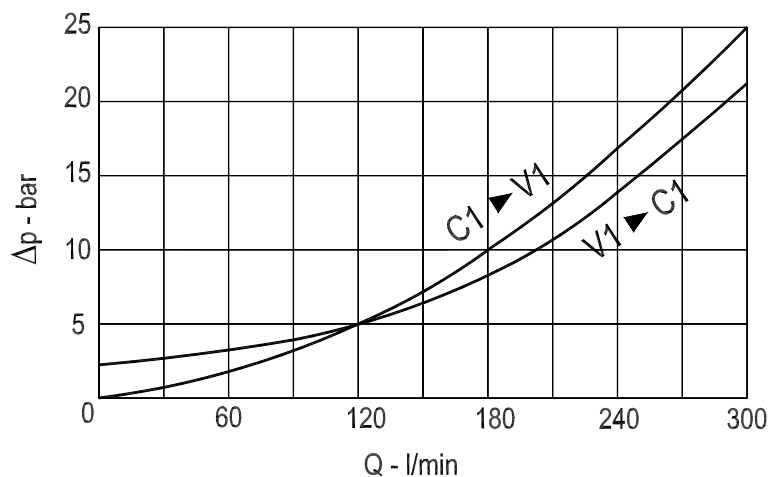

Valvola overcenter bilanciata, versione a cartuccia, cavità metrica
Fully overcenter valve, cartridge version, metric cavity

Rev.04-2010/09

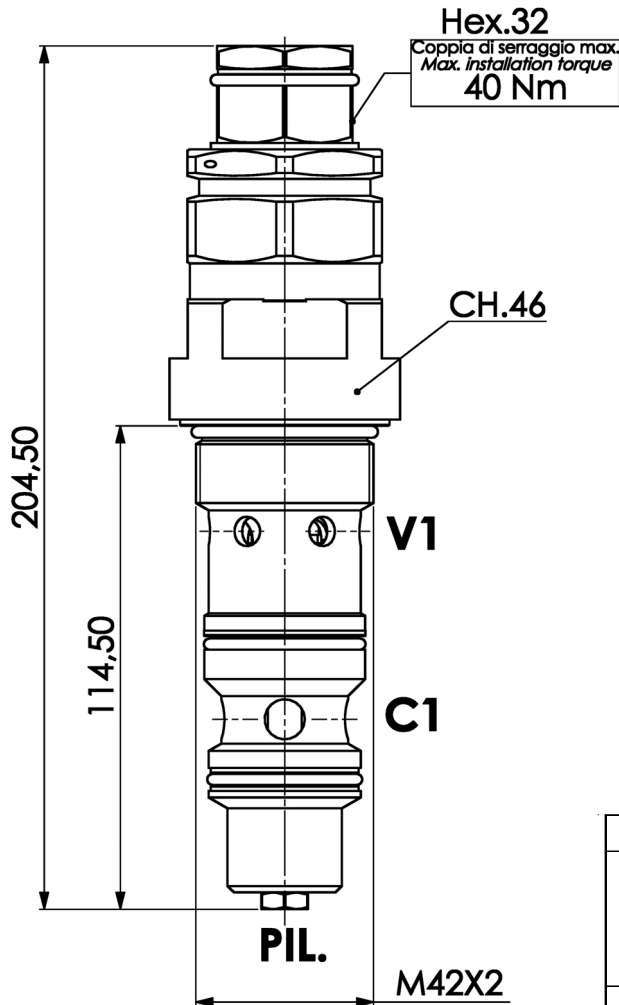

MOLLE - SPRINGS				*
Codice Code	Rapp. pil. Pilot ratio	Campo taratura min.-max. bar Adjustable pressure range bar	Increment. press. bar/giro vite Pressure increase bar/turn	Taratura standard bar Standard setting bar
35	1 : 4	100 - 350	45	280

TIPO TYPE	RAPP. DI PILOTAGGIO PILOT RATIO	CAVITA' CAVITY	COPPIA DI SERRAGGIO INSTALLATION TORQUE	PESO WEIGHT
			Nm	Kg
FPOFB-300-C	1 : 4	32421	246 - 272	1.650

ESEMPIO DI ORDINAZIONE - ORDERING CODE EXAMPLE

F P O F B 3 0 0 C 3 5